

Seul les équipements pour plonger et/ou glisser conçues pour l'usage en piscine doivent être utilisés. Se conformer à la norme BNQ 9461-100/2009 et aux spécifications du fabricant de l'équipement. Pour une meilleure sécurité **nous déconseillons fortement l'utilisation** de tels équipement.

Périmètre	74'	Date	01/Jan/2012
Surface (pi. ca.)	303	Échelle	1/8" = 1'-0"
Volume (Litres)	32 500	#Dessin	AZ1224G-12

Azure 12 x 24 Gauche

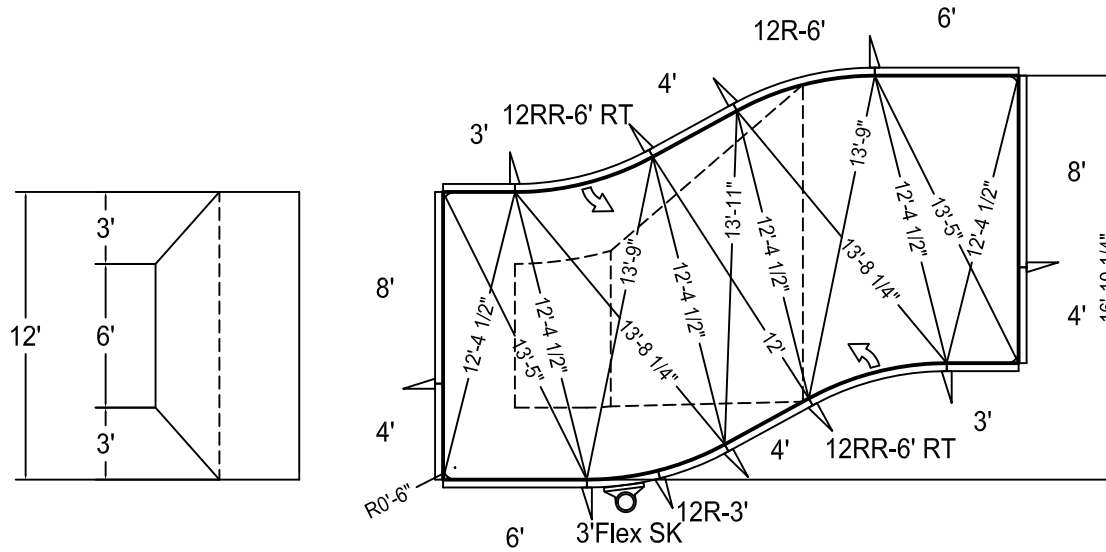

BNQ 9461-100/2009

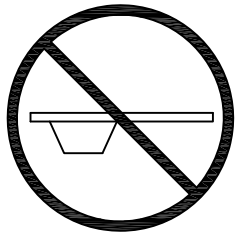

NON CONFORME
pour plongeur

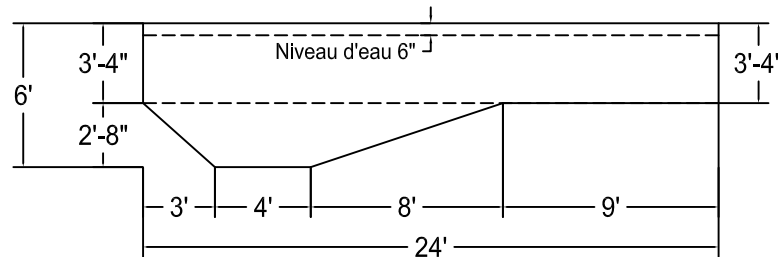

Description	Code Produit	Qté
8' Droit	PAN-000DR96P	2
6' Droit	PAN-000DR72P	2
4' Droit	PAN-000DR48P	4
3' Droit	PAN-000DR36P	2
12R-6'	PAN-144CR72P	1
12R-3'	PAN-144CR36P	1
3' Flex Skimmer	PAN-144CR36F	1
12RR-6' Retour (12' Rev.)	PAN-144RR72I	2
Frame En A	PAN-00000AF	7
Coin 90°	PAN-090COIN	4
Coin 6" de Rayon	PAN-006CR000	4
Stake Rode Paquet de 30	AQ-STAKE50	1
Nuts and bolts Paquet de 50	AQ-NBOLT50	3

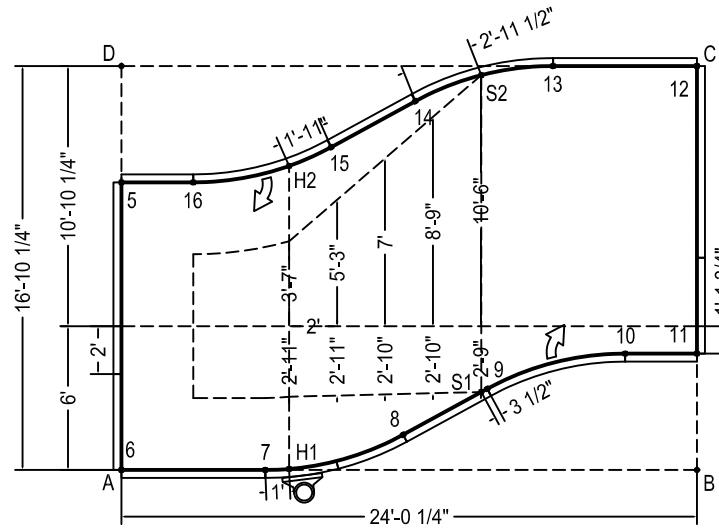

	A	B	C	D
1	13'-5"	21'-7 3/4"	18'-8"	7'-8 1/2"
2	18'-8"	7'-8 1/2"	13'-5"	21'-7 3/4"
3	24'-2 1/4"	31'-10 3/4"	22'-2 1/4"	7'-9"
4	22'-2 1/4"	7'-9"	24'-2 1/4"	31'-10 3/4"
5	12'	26'-10 1/4"	24'-6"	4'-10 1/4"
6	0'	24'-0 1/4"	29'-4"	16'-10 1/4"
7	6'	18'-0 1/4"	24'-8"	17'-10 3/4"
8	11'-10 1/4"	12'-4 1/4"	19'-8"	19'-4 1/4"
9	15'-7 1/2"	9'-4 3/4"	16'-0 3/4"	20'-4 1/4"
10	21'-6 3/4"	5'-8 1/2"	12'-4 1/2"	24'-2 1/2"
11	24'-6"	4'-10 1/4"	12'	26'-10 1/4"
12	29'-4"	16'-10 1/4"	0'	24'-0 1/4"
13	24'-8"	17'-10 3/4"	6'	18'-0 1/4"
14	19'-8"	19'-4 1/4"	11'-10 1/4"	12'-4 1/4"
15	16'-0 3/4"	20'-4 1/4"	15'-7 1/2"	9'-4 3/4"
16	12'-4 1/2"	24'-2 1/2"	21'-6 3/4"	5'-8 1/2"
H1	7'	17'-0 1/4"	23'-11"	18'-2 1/2"
H2	14'-5 3/4"	21'-2 3/4"	17'-6 1/4"	8'-1 3/4"
S1	15'-4 1/2"	9'-6 3/4"	16'-3 3/4"	20'-3 1/4"
S2	22'-3 1/2"	18'-9 1/4"	9'	15'-0 1/4"
A	-	24'-0 1/4"	29'-4"	16'-10 1/4"

